

ProSport 5 & 5/5 Series

Owner's Manual and Installation Guide

English
German
French

Standard Edition 4 stage Battery Charger

WATERPROOF
and
SALTWATER
TESTED

Constructed to:
Marine UL 1236
FCC Class A Part 15

Fully Automatic Charging

Models	Amperage	No. Of Banks	Volts
ProSport 5	5	1 Bank	12
ProSport 5/5	10	2 Banks 12 v 1 bak 24	12/24

IMPORTANT NOTICE

Please save and read all safety, operating and installation instructions before installing or applying AC power

**For all product, installation or service questions please visit
www.sterling-power.com
9am to 5pm (GMT)**

▶ Table Of Contents

	page
Safety Instructions...	1 - 2
ProSport Overview..	4
Installation Guidelines.	4 - 6
Charging Your Batteries...	6 - 7
Maintenance...	7
Trouble Shooting...	8
Specifications	8
Customer Service & Warranty..	

▶ General Safety Instructions

Before connecting your batteries or AC power, read all instructions and cautionary markings on the battery charger and batteries.

CAUTION To reduce the risk of injury; charge only lead acid type rechargeable batteries (lead acid, sealed lead acid, gel cell and AGM). Other types of batteries may burst, causing personal injury. **The Pro Sport is factory set for lead acid and gel batteries**

Do not operate the charger if it has received a sharp blow, direct hit of force, dropped or otherwise damaged in any way.

Do not disassemble the charger. Call the factory directly when service or repair is required. Incorrect assembly may result in risk of electrical shock or fire.

To reduce the risk of electrical shock, remove AC power from the charger prior to any maintenance or cleaning.

WARNING: RISK OF EXPLOSIVE GASES

WORKING IN THE VICINITY OF A LEAD ACID BATTERY IS DANGEROUS. BATTERIES GENERATE EXPLOSIVE GASES DURING NORMAL BATTERY OPERATION. FOR THIS REASON IT IS OF EXTREME IMPORTANCE THAT EACH TIME BEFORE USING YOUR CHARGER YOU FOLLOW THESE SAFETY INSTRUCTIONS.

To reduce risk of battery explosion, follow these instructions and those published by the battery manufacturer, and of any equipment you intend to use in the vicinity of a battery. Review all cautionary markings and labels.

▶ Personal Safety Precautions

Someone should be within the range of your voice or close enough to come to your aid when working near a lead acid battery.

Have plenty of water and soap nearby in case battery acid comes in contact with skin, clothes or eyes.

Wear complete eye protection and clothing protection. Avoid touching eyes while working with a battery.

If battery acid contacts skin or clothing, wash immediately with soap and water. If acid enters the eye(s) flood eye(s) with running cold water for at least 10 minutes and get medical attention immediately.

Personal Safety Precautions Continued

Never smoke or allow a spark or a flame in the vicinity of a battery or engine.

Be extra cautious to reduce risk of dropping a metal tool onto a battery. It may spark or short-circuit the battery or other electrical parts that may cause explosion.

Remove all personal metal items such as rings, bracelets, necklaces, watches, and jewelry when working near a battery. A battery can produce a short circuit high enough to weld a ring or any metal, causing serious burns.

Use the charger for charging lead acid and gel batteries only It is not intended to supply low voltage electrical systems other than in a marine application. Do not use the battery charger to charge dry cell batteries that are commonly used with home appliances. These batteries may burst and cause injury to persons and property.

Never charge a frozen battery.

Safety Precautions Prior to Charging Batteries

If necessary to remove a battery from a boat to charge, always remove grounded terminal from battery first. Make sure all accessories in the boat are off, as to not cause an arc.

Be sure the area around the charger and batteries is well ventilated while the batteries are being charged. Gases can be forcefully blown away using a piece of cardboard or other nonmetallic material as a fan.

Clean battery terminals with full eye protection to prevent corrosion from coming in contact with eyes.

Add distilled water in each cell until electrolyte reaches levels specified by the battery manufacturer. This helps purge excessive gases from cells. Do not overfill. For batteries without caps, carefully follow manufacturer's recharging instructions.

Study all manufacturer's specific precautions, such as removing or not removing cell caps while charging, in addition to rates of charge.

Extension cords should be industrial grade / heavy duty (3 pronged) U.L. approved and grounded. Check extension cord before use for damage, bent prongs, and cuts. Replace if damaged.

Always make your extension cord connection on the charger side first. After connecting the extension cord to the charger then proceed to plug the extension cord to a nearby 240 VAC RCD protected outlet.

Always remove the extension cord from the 240 VAC outlet first when charging is completed followed by unplugging the charger.

▶ General Overview

The charger is a fully Automatic/ Electronic On-board Marine Battery Charger. ProMite is pre-wired for easy installation and is 100% waterproof for fresh and salt water applications.

The Pro Sport Lt incorporates a durable one piece plastic housing. The ProMite offers fully automatic charging which includes a "Float " maintenance mode that is safe for long and short term storage. Pro Sport Lt can be left on indefinitely without harming or over charging your batteries.

Easy to view LED indicators will provide you with AC Power On and Charging Status. The LED Indicators can be seen from the front and side of the charger when installed.

The Pro Sport is available in 2 models and can be used in 12 or 24 volt .

Please attach the DC output cable terminals as illustrated in the installation section of this manual.

▶ General Operation

Install your Pro |Sport Lt - Fully Automatic / Battery Charger to the guidelines in this manual.

Make sure your charger and batteries are properly vented. Connect your extension cord with no AC Power present to the charger and proceed to plug your extension cord in at a nearby 230 v RCD (Ground Fault Circuit Interrupt) outlet.

With your charger plugged in properly, it will automatically charge your batteries while it conditions and extends the life of your batteries. always leave your charger plugged in to reduce sulfate buildup allowing your batteries to be fully charged and maintained until their next use.

▶ AC Power and Charging LED Status Indicators

The ProMite includes two LED indicators as shown below.

Green "AC Power" LED indicator:

When on, the green LED indicates when AC Power is present.

Red " Charging" LED indicator:

When on, the red LED indicates the charger is in its Automatic Charging Mode.

When charging is complete only the green LED will remain on.

▶ Fully Automatic Charging Overview

When the Battery Charger is turned on the green AC power indicator will turn on followed by the red charging LED indicator.

The Automatic Charger will provide the following:

Pro Sport Charging - Red and Green LED On

During this mode the charger will use its available charging amps (as controlled by temperature) until battery voltage is raised to 14.1 VDC (safe for lead acid or gel batteries).

Pro Sport Conditioning - Red and Green LED On

The ProSport will charge batteries to 14.1 VDC to complete charging while conditioning batteries. Upon completion the ProMite will go to into its maintenance mode.

► Fully Automatic Charging Overview Continued

ProSport Float / Maintenance - Green LED Only On

During this mode the red "Charging" LED will turn off indicating that the charging process is over and the charger is now maintaining your batteries on-board. Only the green LED will remain on, indicating Power On / Float-Maintenance mode. A precision 13.5 volts finishing voltage that maintains each battery (step down voltage regulation mode) which is perfect for short or long storage periods and will never overcharge your batteries.

Note: The only LED Indicator that will be on during the maintenance mode will be the green "Power" LED indicator.

Typical Average Voltage

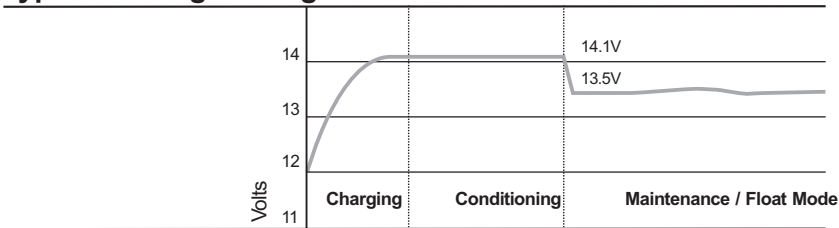

► Installation

All ProSport Battery Chargers are designed to be permanently mounted on-board, and can be mounted vertically or horizontally.

Always mount your ProSport Lt Charger in a compartment area that can be properly ventilated during use.

Do NOT mix battery types on-board. All batteries should be of the same age and in good operating condition.

Do NOT make any electrical connections to the charger or batteries until the following steps are completed:

11 Easy to follow installation steps:

1. Select a mounting location that allows for free air ventilation with a minimum of 8 inches of clear unobstructed space around and in front of the Battery Charger. Open all battery and engine compartments and ventilate for at least 15 minutes before starting the installation of the Charger.

Installation Continued

- 2 . Confirm the selected mounting location allows for a minimum of 200 mm inches of free space around front and sides of the charger. Do not install charger on carpeted , upholstered , vinyl or varnished areas. Be sure to place the charger in an accessible area where all indicators are viewable. Confirm all battery cables can reach each of the batteries.
3. Using the charger as a template use a small awl or screwdriver to mark the position of each mounting hole.
4. Using a 1/8" drill bit, drill pilot holes in the (4) marked locations as described in step 3. Apply a silicon sealer in each of the mounting locations to waterproof the screw holes.
5. Position the charger over the mounting holes and secure with a power screwdriver by installing 4 marine grade or stainless steel screws. (mounting screws) **not included**

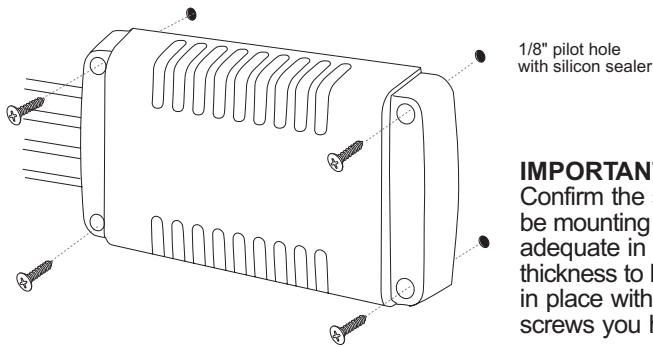

IMPORTANT NOTICE

Confirm the surface you will be mounting the charger to is adequate in strength and thickness to hold the charger in place with the mounting screws you have selected.

6. Prepare each battery in advance by cleaning each terminal post with a wire brush until a shiny surface is obtained.

IMPORTANT NOTICE

As you prepare to attach the positive (red) and negative (yellow or black wires) to the batteries there will be brief low power spark that is generated as you make the connection. This is due to the high frequency capacitors taking a charge. Make sure the (black or yellow) wires are connected as illustrated to the negative side of the battery and the red wires are connected to the positive side of the battery.

7. Run your cables free from sharp objects and hold each of them in place with cable ties. Coil excess cable, do not cut or shorten the length of the cables as there are in-line fuses located 4 inches from the end of each red (positive) cable. These fuses are in place to protect the charger and output cables in the event of a short or reverse polarity.

8. Connect the DC output cables as illustrated on page 8. Make sure the (black or yellow) wires are connected as illustrated to the negative side of the battery and the red wires are connected to the positive side of the battery.

9. Make sure all DC connections are tight and correct.

- 10 Locate the AC power cord in an open-air area of your boat at least 21 inches from the charger, batteries and fuel fill lines.

You are now connected and charging your batteries. View the LED indicators. Assuming your batteries are discharged you should observe both the green "Power" LED and the red "Charging" LED on, indicating charging mode is in process.

Lead Acid (Flooded) / Gel Charging Profile

The Pro Sport Lt Battery Charger is factory set with a safe charging profile for lead acid (flooded) and gel batteries.

ProSport Series Wiring Diagrams

IMPORTANT NOTICE

If only two batteries are used with a 3 bank charger, than connect the unused output cable to either one of the two batteries, as instructed in item 8 above

Always connect each charger output to a single 12V battery even if the batteries are wired series for 24V or 24V with an engine battery.

ProSport Series Wiring Diagrams

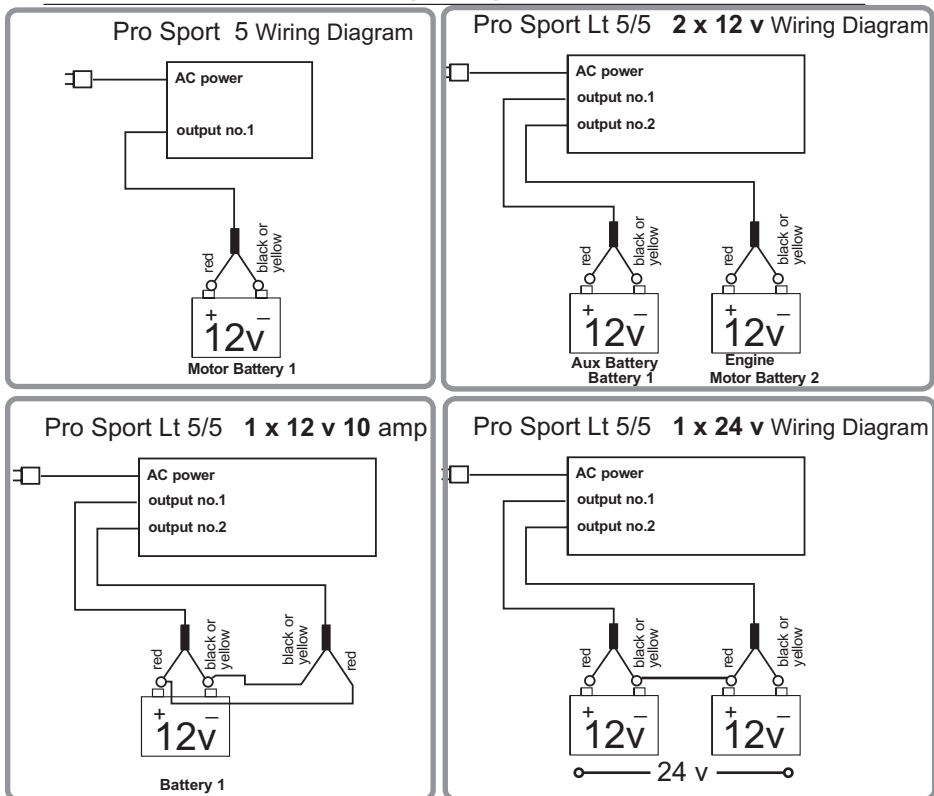

Charging Batteries

The Pro Sport Series is designed to charge and maintain your batteries. Please follow these steps each time you use your ProMite Charger:

1. Open all battery compartments and ventilate for at least 15 minutes before applying AC power to your charger. While charging your batteries make sure to keep your battery compartment open allowing for free air ventilation.

▶ Charging Batteries Continued

3. Connect a heavy duty extension cord to the ProSport charger first. After connecting the extension cord to the charger then proceed to plug the extension cord to a nearby 230 v RCD protected (Ground Fault Circuit Interrupt) outlet.
4. Observe the on-board LED indicators for a solid green and red Indication. This will tell you the batteries are in the charging process.
5. Charge your batteries until only the green LED indicator remains on. This indicates the charging process is completed and your batteries are fully charged and are now being maintained in a gentle float / storage mode. (recommended while your boat is not in use). The charger can be left on in this mode indefinitely and will never overcharge your batteries. *Refer to the page 4.*
6. When ready to use your boat, unplug the extension cord from the 230 v AC outlet first, followed by unplugging the charger.

▶ Important Notice: FCC Class A Part 15 Notification.

YourPro Sport L Battery Charger has been designed and tested to comply with FCC Class A part 15. and CE These regulations are to provide adequate protection against harmful interference while operated in a commercial application. If in a residential setting you are encountering interference with TV and radio reception. Simply remove AC from the charger to confirm if your battery charger is causing interference. End user can explore the following to minimize interference.

- 1) Chose a different AC circuit to power your Charger
- 2) Make sure your outlet is properly grounded
- 3) Re-position receiving antenna
- 4) Purchase a separate AC line filter

Owner's Periodic Maintenance Guide

Item: Battery Connections	
Process:	Clean and tighten all battery connections. Follow battery manufacturer's instructions for cleaning a battery. Clean all battery terminals with a wire brush where required and tighten all battery connections.
When:	Monthly
Item: Battery Electrolyte	
Process:	Per battery manufactures instructions monitor and maintain proper levels of distilled water in each battery.
When:	Monthly
Item: ProMite DC Output Wiring	
Process:	Visually inspect all wiring for cuts and abrasions. Contact ProMariner if charger needs to be serviced with new wiring.
When:	Monthly
Item: AC Power Cord and Mounting Hardware Inspection	
Process:	Process: Visually inspect the AC power cord. Confirm ground blade is present and all plug blades are in good conditions and not bent out of place. Check all mounting hardware to ensure there is no loose hardware. Tighten were required.
When:	Monthly

▶ Trouble Shooting Guide

No Red or Green LED Indicator

Check for loss of AC power at the 230VAC Outlet. Confirm the RCD (Ground Fault Circuit Interrupter) has not tripped. Check with a meter to confirm 230 v a/c is present at the end of your extension cord.

Confirm all charger cables are installed with the correct polarity connections at each battery and that all connections are clean and tight.

With the AC Power removed and the engine off, check the charge level of each battery with a DC meter or Handheld DC Tester. If there is no charge level indication for a battery, check each battery with a hydrometer to determine if it has one or more bad cells. (batteries should always be replaced in sets, and always the same type.)

If everything above checks out ok, contact ProMariner for product service.

Battery is Not Charging, Red and Green Indicator is “on”

Confirm all charger cables are installed with the correct polarity connections at each battery, and that all connections are clean and tight. *Reverse polarity connections will blow output fuse, resulting in no output voltage.*

With the charger on, read DC voltage at each battery. If any of the readings are less than 13 VDC Proceed with the following:

A. Disconnect AC power at the 230 VAC outlet.

B. Remove charger cables from each battery.

C. Reconnect AC power and read DC Voltage across each output cable, if output voltage is approximately 14.1DC the charger is ok and each battery should be tested with a hydrometer with the charger and engine off to determine if one or more batteries have bad cells. (batteries should always be replaced in sets, and always the same type.)

D. If there is no output when trying to read DC voltage check each output fuse and replace as needed.

If the DC voltage at each charger output is less than 13.0 volts contact Sterling Power for product service.

▶ Specifications

model	volts	amps	banks	DC cable L	size L x W x H mm	Est. weight	AC in
Pro Sport	12	5	1	1.5 m	75 x 150 x 65	2.5 kg	180-260
Pro Sport	12 & 24	10	2/2	1 x 1.5 m	230 x 130 x 90	3.5 kg	180-260

▶ Customer Service & Warranty

We are committed to customer satisfaction and value your business. If at any time during the warranty period you experience a problem with your new Pro Sport Battery Charger simply contact us www.sterling-power.com

PROMITE LIMITED TWO-YEAR FACTORY WARRANTY

This charge model is guaranteed against defects in material and workmanship to the original consumer in normal use for 2 years from the date of purchase. Sterling Power Products will at its discretion repair or replace free of charge any defects in material or workmanship. The following conditions apply:

- Warranty is calculated from the date on the purchase invoice
- Warranty void if unauthorized repairs attempted.
- Customer is responsible for returning the product to Sterling power products.
Inbound shipping costs must be prepaid. The warrantee is at the factory
- This warranty does not cover blemishes due to normal wear and tear or damaged caused by accidents, abuse, alterations or misuse.
- Cosmetic repairs can be done at owner's request and expense.

Purchase or other acceptance of the product shall be on the condition and agreement that Sterling Power Products SHALL NOT BE LIABLE FOR INCIDENTAL OR CONSEQUENTIAL DAMAGES OF ANY KIND. (Some states do not allow the exclusion or limitation of incidental or consequential damages, so the above limitations may not apply to you.) This warranty is made in lieu of all other obligations or liabilities on the part of Sterling Power Products. Sterling Power Products neither assumes nor authorizes any person for any obligation or liability in connection with the sale of this product.

To make a claim under warranty, simply contact Sterling Power Products at www.sterling-power.com identifying the product and giving its locations. Follow the company's return instructions, which will then be provided by the company. Sterling Power will make its best effort to repair or replace the product, if found defective within the terms of the warranty, within (10) days after return of the product to the company.

Due to the ever expanding nature of this company (5 factories in 12 years) there is always a current information problem.

Each time we move to a larger factory, the telephone numbers and address change, this leaves all our literature and instructions out of date, so we now only print out web site where all the latest information can be obtained.

www.sterling-power.com

ProSport 5 & 5/5 Series

Handbuch und Installationsanleitung

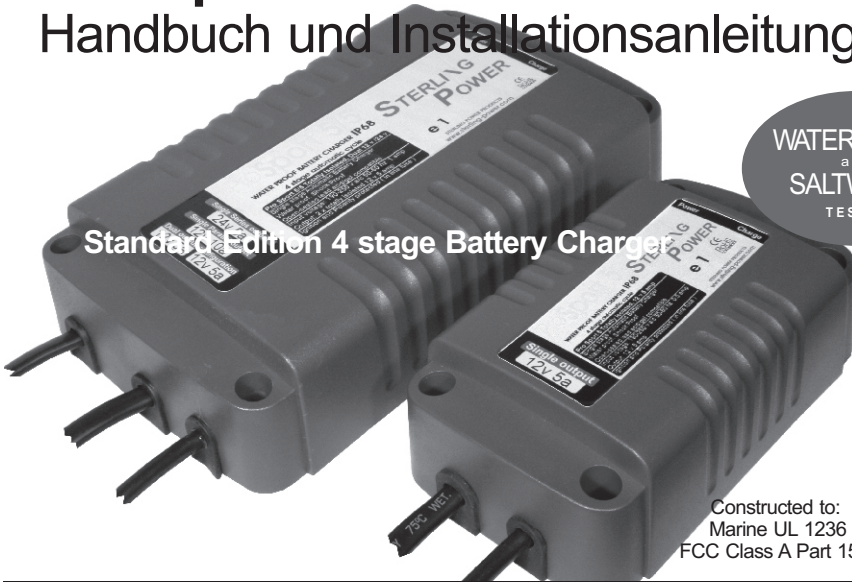

Standard Edition 4 stage Battery Charge

WATERPROOF
and
SALTWATER
TESTED

Constructed to:
Marine UL 1236
FCC Class A Part 15

V o l l a u t o m a t i s c h e s L a d e n

Modelle	Ampere	Batteriebanken	Volt
ProSport 5	5	1 Bank	12
ProSport 5/5	10	2 Bänke12V, 1 Bank 24V	12/24

ACHTUNG:

Bitte speichern und lesen Sie alle Sicherheits-,Bedienungs- und Installationsanleitungen bevor sie AC Strom installieren oder einschalten

Für alle Produkt-, Installations- oder Betriebsfragen,bitte gehen Sie zu www.sterling-power.com 9-17Uhr (GMT)

► Inhalt

Seite

Sicherheitsanleitung...	1 - 2
ProSport Überblick..	4
Installationsrichtlinien..	4 - 6
Batterien laden...	6 - 7
Wartung...	7
Fehlerhilfe...	8
Spezifikationen	8
Kundenservice & Gewährleistung..	

► Allgemeine Sicherheitshinweise

Bevor Sie Ihre Batterien an den AC Strom anschliessen, lesen Sie alle Anleitungen und Warnkennzeichnungen am Ladegerät und den Batterien.

VORSICHT - zur Risikoreduktion: laden Sie nur wiederaufladbare Blei-Säure Batterien (Blei-Säure, geschlossene Blei-Säure, Gelzelle und AGM). Andere Arten von Batterien könnten aufbrechen und Verletzungen hervorrufen.

Das ProSport hat eine Werkseinstellung für Blei-Säure und Gel Batterien

Benützen Sie Das Ladegerät nicht falls es einen heftigen Schlag oder kräftigen Stoß erlitten hat, fallen gelassen wurde, oder anderwertig beschädigt ist.

Nehmen Sie den Lader nicht auseinander. Rufen Sie direkt beim Werk an wenn Service oder Reparatur benötigt werden. Bei falschem Zusammenbau riskieren Sie einen . elektrischen Schock oder Feuer.

Um dieses Risiko zu reduzieren, entfernen Sie den AC Strom vom Lader bevor jeder Reinigung oder Wartung.

WARNUNG: RISIKO EXPLOSIVER GASE
ES IST GEFÄHRLICH NAHE ZU EINER BLEI-SÄURE BATTERIE ZU ARBEITEN. BATTERIEN ERZEUGEN EXPLOSIVE GASE BEI NORMALEM BATTERIE-BETRIEB. DAHER IST ES EXTREM WICHTIG VOR JEDEM GEBRAUCH DES LADEGERÄTES DASS SIE DIESEN SICHERHEITSANLEITUNGEN FOLGEN.

Um das Risiko einer Batterieexplosion zu reduzieren, folgen Sie dieser Anleitung und der des Batterieherstellers, und denen jedes Equipments welches Sie in der Nähe einer Batterie verwenden wollen.

Lesen Sie alle Warnhinweise und Aufkleber auf den Geräten.

► Persönliche Sicherheitsvorkehrungen

Wenn Sie in der Nähe einer Blei-Säure Batterie arbeiten, sollte jemand in Hörweite von Ihnen sein um zu Ihrer Hilfe kommen zu können.

Sie sollten genug Wasser und Seife bereit haben, falls Batteriesäure mit Ihrer Haut, Kleidung oder Ihren Augen in Kontakt kommt.

Tragen Sie kompletten Augenschutz. Vermeiden Sie Ihre Augen zu berühren wenn Sie mit einer Batterie arbeiten.

Falls Batteriesäure an Ihre Haut oder Kleidung kommt, waschen sie sofort mit Wasser und Seife. Falls Säure in die Augen kommt, spülen Sie für mindestens 10 Minuten und suchen Sie sofort medizinische Hilfe auf.

Persönliche Sicherheitsvorkehrungen fortgesetzt

Bringen Sie niemals eine brennende Zigarette, eine offene Flamme oder Funken in die Nähe einer Batterie oder eines Motors.

Seien Sie besonders wachsam dass kein Metallwerkzeug auf die Batterie fallen kann. Dies kann Funken erzeugen oder die Batterie oder andere Geräte kurzschließen. Dies kann eine Explosion hervorrufen.

Entfernen Sie alle persönlichen Gegenstände die metallisch sind. zB Ringe, Armbänder, Halsketten, Uhren und Schmuck wenn Sie mit/bei einer Batterie arbeiten.

Eine Batterie kann einen Kurzschluss erzeugen der hoch genug Metall zu verschweißen, was zu ernsthaften Verbrennungen führt.

Verwenden Sie das Ladegerät nur um Blei-Säure und Gelbatterien zu laden. Es ist nicht vorgesehen elektrische Systeme mit niedriger Spannung zu speisen, ausser in einer Marine-Anwendung. Verwenden Sie den Lader nicht um Trockenbatterien zu laden welche im Allgemeinen für Haushaltsgeräte verwendet werden. Diese Batterien könnten platzen und Verletzungen oder Schaden anrichten.

Laden Sie niemals eine gefrorene Batterie.

Sicherheitsvorkehrungen vor dem Laden der Batterien

Falls es notwendig ist eine Batterie zum Laden vom Boot zu nehmen, entfernen Sie immer den geerdeten Batteriepol zuerst. Stellen Sie sicher dass alles Zubehör auf dem Boot abgeschaltet ist, um eine Bogenentladung zu verhindern.

Während des Ladens sollten Batterie und Ladegerät immer gut belüftet sein. Gase können durch Fächern eines Stück Kartons oder ähnlichem, nicht metallischem Material vertrieben werden.

Reinigen Sie Batteriepole mit vollem Augenschutz damit Korrosion nicht in die Augen gelangen kann.

Füllen Sie destilliertes Wasser in jede der Zellen bis das Electrolyt die herstellerbestimmten Levels erreicht. Dies hilft, überflüssige Gase aus den Zellen zu vertreiben. Überfüllen Sie nicht. Bei Batterien ohne Verschlusskappen, folgen Sie bitte genau den Ladeanleitungen des Herstellers.

Beachten Sie alle Vorsichtsmaßnahmen des Herstellers, wie zB das Entfernen oder Nicht-Entfernen der Zellverschlusskappen während des Ladens und die Lademessungen.

Verlängerungskabel sollten industriellen Standard haben und hochleistungsfähig sein (dreiadriges Kabel) U.L. anerkannt und geerdet. Überprüfen Sie das Verlängerungskabel vor Gebrauch auf Schäden, verbogene Leitungen und Schnitte. Ersetzen Sie es, falls beschädigt.

Die Verlängerung immer zuerst auf der Ladegerät-Seite anschließen. Danach stecken Sie es an einem 240VAC RCD geschützten Anschluss an.
Entfernen Sie das Verlängerungskabel immer zuerst vom 240VAC Abschluss wenn das Laden beendet ist, dann können Sie das Ladegerät abstecken.

Allgemeine Übersicht

Das Ladegerät ist ein voll automatisches, elektronisches On-Board Marine Batterieladegerät. ProMite ist vor-verkabelt und ist 100% wasserdicht, für Frisch- und Salzwasser Anwendungen.

Das ProSport Lt umfasst eine Plastikschaale die aus einem Stück besteht. Das ProMite bietet vollautomatisches Laden mit einem Erhaltungsladungs-Modus welcher für Kurz- und langfristige Lagerung geeignet ist. ProSport Lt kann für unbegrenzte Zeit angelassen sein, ohne Ihre Batterien zu schädigen oder zu überladen.

Leicht sichtbare LEDs zeigen Ihnen AC Power On und den Ladestatus. Nach Installation sind die LED Anzeigen von Vorne und der Seite des Laders sichtbar. Das ProSport ist erhältlich in 2 Modellen und kann auf 12V oder 24V verwendet werden.
Bitte bringen Sie die DC Ausgangs-Kabelanschlüsse wie im Einbau-Abschnitt dieses Handbuchs illustriert, an.

Allgemeine Bedienung

Installieren Sie Ihr ProSport L-Vollautomatisches Ladegerät nach den Richtlinien in diesem Handbuch.

Stellen Sie gute Belüftung Ihres Laders und der Batterien sicher. Verbinden Sie Ihre Verlängerung ohne angeschlossenen AC Strom zum Lader und dann zu einer 240V RCD (Erdungsfehler Kreislauf-Unterbrechend) Buchse.

Sobald das Ladegerät ordentlich angeschlossen ist, wird es automatisch Ihre Batterien laden und sie zugleich aufbereiten und deren Leben verlängern. Lassen Sie Ihr Ladegerät immer angeschlossen um Sulfatbildung zu reduzieren. Somit werden Ihre Batterien vollständig geladen und bis zum nächsten Gebrauch auch so erhalten.

AC Power und Ladung LED Indikatoren

Das ProMite inkludiert 2 LED Indikatoren, wie unten angeführt.

Grüner "AC Power" LED Indikator:

wenn an, das grüne LED zeigt wenn Strom vorhanden ist

Roter "Laden" Indikator:

wenn an, das rote LED zeigt dass der Lader im automatischen

Lademodus ist. Wenn vollständig geladen, dann bleibt nur das grüne

LED an.



The ProMite includes two LED indicators as shown below.

Green "AC Power" LED indicator:

When on, the green LED indicates when AC Power is present.

Red "Charging" LED indicator:

When on, the red LED indicates the charger is in its Automatic Charging Mode.

When charging is complete only the green LED will remain on.

▶ Fully Automatic Charging Overview

When the Battery Charger is turned on the green AC power indicator will turn on followed by the red charging LED indicator.

The Automatic Charger will provide the following:

Pro Sport Charging - Red and Green LED On

During this mode the charger will use its available charging amps (as controlled by temperature) until battery voltage is raised to 14.1 VDC (safe for lead acid or gel batteries).

Pro Sport Conditioning - Red and Green LED On

The ProSport will charge batteries to 14.1 VDC to complete charging while conditioning batteries. Upon completion the ProMite will go to into its maintenance mode.

► Fully Automatic Charging Overview Continued

ProSport Float / Maintenance - Green LED Only On

During this mode the red "Charging" LED will turn off indicating that the charging process is over and the charger is now maintaining your batteries on-board. Only the green LED will remain on, indicating Power On / Float-Maintenance mode. A precision 13.5 volts finishing voltage that maintains each battery (step down voltage regulation mode) which is perfect for short or long storage periods and will never overcharge your batteries.

Note: The only LED Indicator that will be on during the maintenance mode will be the green "Power" LED indicator.

Typical Average Voltage

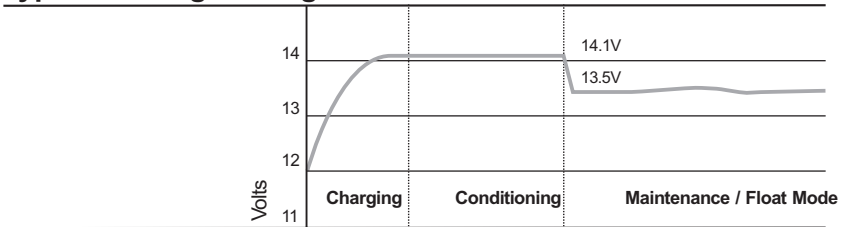

► Installation

All ProSport Battery Chargers are designed to be permanently mounted on-board, and can be mounted vertically or horizontally.

Always mount your ProSport Lt Charger in a compartment area that can be properly ventilated during use.

Do NOT mix battery types on-board. All batteries should be of the same age and in good operating condition.

Do NOT make any electrical connections to the charger or batteries until the following steps are completed:

11 Easy to follow installation steps:

1. Select a mounting location that allows for free air ventilation with a minimum of 8 inches of clear unobstructed space around and in front of the Battery Charger. Open all battery and engine compartments and ventilate for at least 15 minutes before starting the installation of the Charger.

Installation Continued

- 2 . Confirm the selected mounting location allows for a minimum of 200 mm inches of free space around front and sides of the charger. Do not install charger on carpeted , upholstered , vinyl or varnished areas. Be sure to place the charger in an accessible area where all indicators are viewable. Confirm all battery cables can reach each of the batteries.
3. Using the charger as a template use a small awl or screwdriver to mark the position of each mounting hole.
4. Using a 1/8" drill bit, drill pilot holes in the (4) marked locations as described in step 3. Apply a silicon sealer in each of the mounting locations to waterproof the screw holes.
5. Position the charger over the mounting holes and secure with a power screwdriver by installing 4 marine grade or stainless steel screws. (mounting screws) **not included**

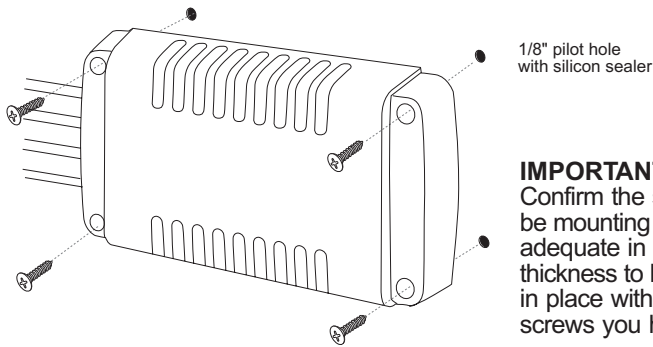

IMPORTANT NOTICE

Confirm the surface you will be mounting the charger to is adequate in strength and thickness to hold the charger in place with the mounting screws you have selected.

6. Prepare each battery in advance by cleaning each terminal post with a wire brush until a shiny surface is obtained.

IMPORTANT NOTICE

As you prepare to attach the positive (red) and negative (yellow or black wires) to the batteries there will be brief low power spark that is generated as you make the connection. This is due to the high frequency capacitors taking a charge. Make sure the (black or yellow) wires are connected as illustrated to the negative side of the battery and the red wires are connected to the positive side of the battery.

7. Run your cables free from sharp objects and hold each of them in place with cable ties. Coil excess cable, do not cut or shorten the length of the cables as there are in-line fuses located 4 inches from the end of each red (positive) cable. These fuses are in place to protect the charger and output cables in the event of a short or reverse polarity.

8. Connect the DC output cables as illustrated on page 8. Make sure the (black or yellow) wires are connected as illustrated to the negative side of the battery and the red wires are connected to the positive side of the battery.

9. Make sure all DC connections are tight and correct.

- 10 Locate the AC power cord in an open-air area of your boat at least 21 inches from the charger, batteries and fuel fill lines.

You are now connected and charging your batteries. View the LED indicators. Assuming your batteries are discharged you should observe both the green "Power" LED and the red "Charging" LED on, indicating charging mode is in process.

Lead Acid (Flooded) / Gel Charging Profile

The Pro Sport Lt Battery Charger is factory set with a safe charging profile for lead acid (flooded) and gel batteries.

ProSport Series Wiring Diagrams

IMPORTANT NOTICE

If only two batteries are used with a 3 bank charger, than connect the unused output cable to either one of the two batteries, as instructed in item 8 above

Always connect each charger output to a single 12V battery even if the batteries are wired series for 24V or 24V with an engine battery.

ProSport Series Wiring Diagrams

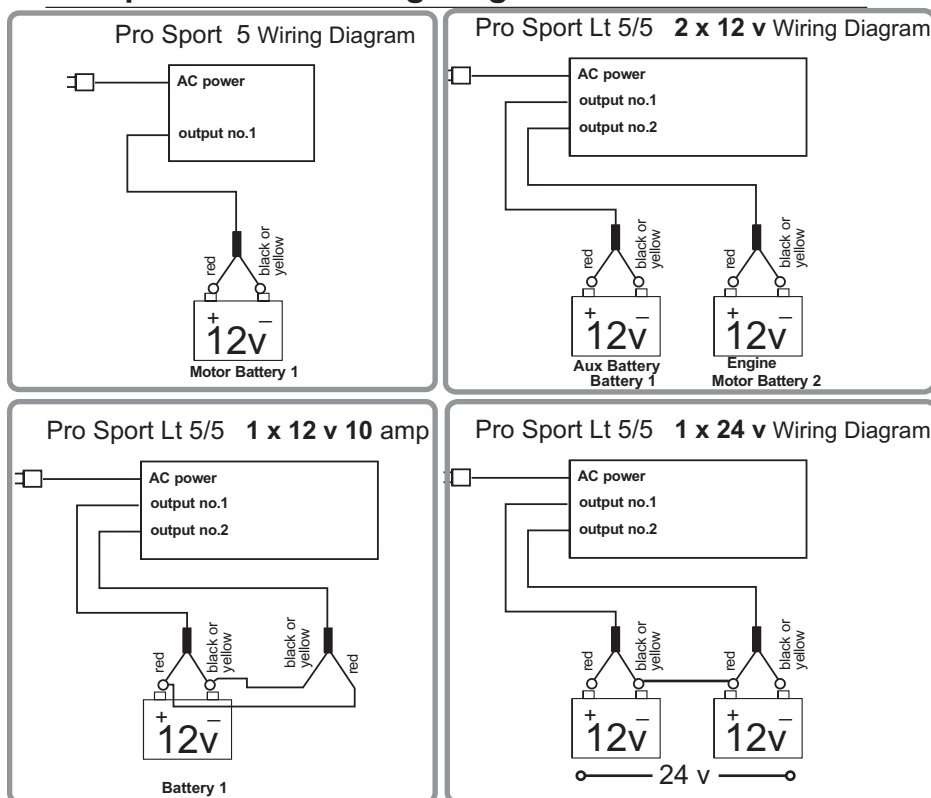

Charging Batteries

The Pro Sport Series is designed to charge and maintain your batteries. Please follow these steps each time you use your ProMite Charger:

1. Open all battery compartments and ventilate for at least 15 minutes before applying AC power to your charger. While charging your batteries make sure to keep your battery compartment open allowing for free air ventilation.

▶ Charging Batteries Continued

3. Connect a heavy duty extension cord to the ProSport charger first. After connecting the extension cord to the charger then proceed to plug the extension cord to a nearby 230 v RCD protected (Ground Fault Circuit Interrupt) outlet.
4. Observe the on-board LED indicators for a solid green and red Indication. This will tell you the batteries are in the charging process.
5. Charge your batteries until only the green LED indicator remains on. This indicates the charging process is completed and your batteries are fully charged and are now being maintained in a gentle float / storage mode. (recommended while your boat is not in use). The charger can be left on in this mode indefinitely and will never overcharge your batteries. *Refer to the page 4.*
6. When ready to use your boat, unplug the extension cord from the 230 v AC outlet first, followed by unplugging the charger.

▶ Important Notice: FCC Class A Part 15 Notification.

YourPro Sport L Battery Charger has been designed and tested to comply with FCC Class A part 15. and CE These regulations are to provide adequate protection against harmful interference while operated in a commercial application. If in a residential setting you are encountering interference with TV and radio reception. Simply remove AC from the charger to confirm if your battery charger is causing interference. End user can explore the following to minimize interference.

- 1) Chose a different AC circuit to power your Charger
- 2) Make sure your outlet is properly grounded
- 3) Re-position receiving antenna
- 4) Purchase a separate AC line filter

Owner's Periodic Maintenance Guide

Item: Battery Connections	
Process:	Clean and tighten all battery connections. Follow battery manufacturer's instructions for cleaning a battery. Clean all battery terminals with a wire brush where required and tighten all battery connections.
When:	Monthly
Item: Battery Electrolyte	
Process:	Per battery manufactures instructions monitor and maintain proper levels of distilled water in each battery.
When:	Monthly
Item: ProMite DC Output Wiring	
Process:	Visually inspect all wiring for cuts and abrasions. Contact ProMariner if charger needs to be serviced with new wiring.
When:	Monthly
Item: AC Power Cord and Mounting Hardware Inspection	
Process:	Process: Visually inspect the AC power cord. Confirm ground blade is present and all plug blades are in good conditions and not bent out of place. Check all mounting hardware to ensure there is no loose hardware. Tighten were required.
When:	Monthly

▶ Trouble Shooting Guide

No Red or Green LED Indicator

Check for loss of AC power at the 230VAC Outlet. Confirm the RCD (Ground Fault Circuit Interrupter) has not tripped. Check with a meter to confirm 230 v a/c is present at the end of your extension cord.

Confirm all charger cables are installed with the correct polarity connections at each battery and that all connections are clean and tight.

With the AC Power removed and the engine off, check the charge level of each battery with a DC meter or Handheld DC Tester. If there is no charge level indication for a battery, check each battery with a hydrometer to determine if it has one or more bad cells. (batteries should always be replaced in sets, and always the same type.)

If everything above checks out ok, contact ProMariner for product service.

Battery is Not Charging, Red and Green Indicator is “on”

Confirm all charger cables are installed with the correct polarity connections at each battery, and that all connections are clean and tight. *Reverse polarity connections will blow output fuse, resulting in no output voltage.*

With the charger on, read DC voltage at each battery. If any of the readings are less than 13 VDC Proceed with the following:

A. Disconnect AC power at the 230 VAC outlet.

B. Remove charger cables from each battery.

C. Reconnect AC power and read DC Voltage across each output cable, if output voltage is approximately 14.1DC the charger is ok and each battery should be tested with a hydrometer with the charger and engine off to determine if one or more batteries have bad cells. (batteries should always be replaced in sets, and always the same type.)

D. If there is no output when trying to read DC voltage check each output fuse and replace as needed.

If the DC voltage at each charger output is less than 13.0 volts contact Sterling Power for product service.

▶ Specifications

model	volts	amps	banks	DC cable L	size L x W x H mm	Est. weight	AC in
Pro Sport	12	5	1	1.5 m	75 x 150 x 65	2.5 kg	180-260
Pro Sport	12 & 24	10	2/2	1 x 1.5 m	230 x 130 x 90	3.5 kg	180-260

▶ Customer Service & Warranty

We are committed to customer satisfaction and value your business. If at any time during the warranty period you experience a problem with your new Pro Sport Battery Charger simply contact us www.sterling-power.com

PROMITE LIMITED TWO-YEAR FACTORY WARRANTY

This charge model is guaranteed against defects in material and workmanship to the original consumer in normal use for 2 years from the date of purchase. Sterling Power Products will at its discretion repair or replace free of charge any defects in material or workmanship. The following conditions apply:

- Warranty is calculated from the date on the purchase invoice
- Warranty void if unauthorized repairs attempted.
- Customer is responsible for returning the product to Sterling power products.
Inbound shipping costs must be prepaid. The warrantee is at the factory
- This warranty does not cover blemishes due to normal wear and tear or damaged caused by accidents, abuse, alterations or misuse.
- Cosmetic repairs can be done at owner's request and expense.

Purchase or other acceptance of the product shall be on the condition and agreement that Sterling Power Products SHALL NOT BE LIABLE FOR INCIDENTAL OR CONSEQUENTIAL DAMAGES OF ANY KIND. (Some states do not allow the exclusion or limitation of incidental or consequential damages, so the above limitations may not apply to you.) This warranty is made in lieu of all other obligations or liabilities on the part of Sterling Power Products. Sterling Power Products neither assumes nor authorizes any person for any obligation or liability in connection with the sale of this product.

To make a claim under warranty, simply contact Sterling Power Products at www.sterling-power.com identifying the product and giving its locations. Follow the company's return instructions, which will then be provided by the company. Sterling Power will make its best effort to repair or replace the product, if found defective within the terms of the warranty, within (10) days after return of the product to the company.

Due to the ever expanding nature of this company (5 factories in 12 years) there is always a current information problem.

Each time we move to a larger factory, the telephone numbers and address change, this leaves all our literature and instructions out of date, so we now only print out web site where all the latest information can be obtained.

www.sterling-power.com

ProSport 5 & 5/5 Series

notice d'installation et d'utilisation

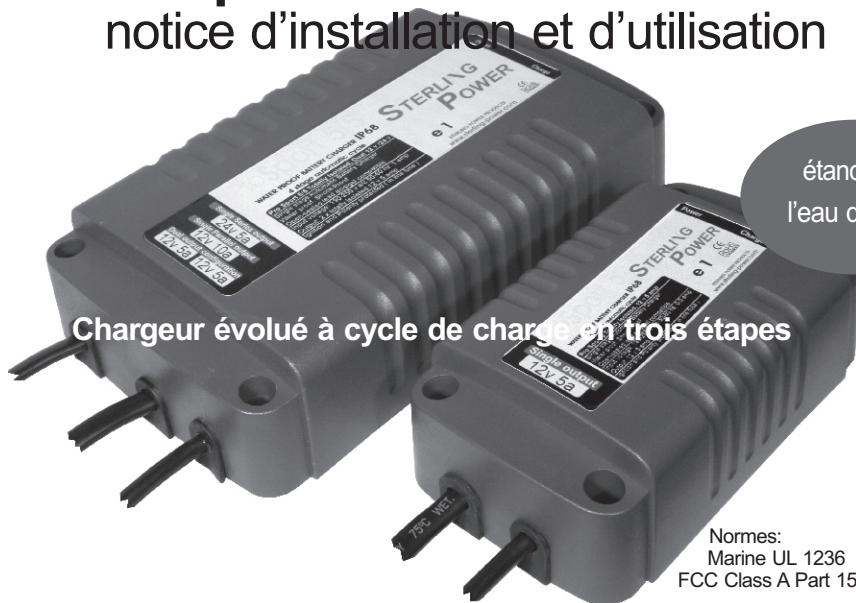

Chargeur évolué à cycle de charge en trois étapes

étanche à
l'eau de mer

Normes:
Marine UL 1236
FCC Class A Part 15

Chargeur automatique

Modèle	Amperes	No. de parcs batteries	Tension
ProSport 5	5	1 Parc	12
ProSport 5/5	10	2 Parcs 12V / 1 Parc 24V	12/24

Note importante

Il est fortement recommandé de lire la notice avant de commencer l'installation.

Pour toute question relative au produit, consultez votre revendeur ou visitez le site www.sterling-power.com.

Table des matières

	page
Instructions de sécurité	1
Description du produit .	2
Instructions d'installation	3 - 5
Recharge des batteries	5 - 6
Maintenance	7
Dépannage	7
Spécifications	7
Garantie et support	8

► **Instructions générales de sécurité**

Avant de connecter les batteries et de brancher le chargeur, veuillez lire les instructions de montage et de sécurité.

Attention: Ce chargeur a été conçu pour recharger les batteries au plomb (AGM, gel, sans entretien ou plomb ouvert). Il ne faut pas l'utiliser pour recharger d'autres types de batteries.

Ne pas utiliser le chargeur si celui-ci a été détérioré par une surtension ou un choc majeur.

Ne pas ouvrir le chargeur : pour toute maintenance, il faut le retourner à votre revendeur.

Avant toute opération, assurez-vous d'avoir débranché le chargeur.

Précautions lors de la manipulation des batteries:

Si l'acide des batteries vient en contact avec votre peau ou vos vêtements, il faut rincer abondamment à l'eau douce.

Lors de la manipulation des batteries, il est recommandé de porter des lunettes de protection. Si de l'acide vient au contact de vos yeux, rincer abondamment et consulter un médecin.

► Descriptif général

Ce chargeur est un chargeur complètement automatisé. Il est précâblé pour une installation facile. Il est complètement étanche à l'eau douce et à l'eau salée. Le chargeur est protégé par un boîtier en plastique robuste. Il dispose d'un cycle de charge complètement automatisé en trois étapes. En particulier, il dispose d'un cycle d'entretien et peut être laissé branché en permanence aux batteries sans aucune contre indication. Des indicateurs à leds donneront une vision précise de l'état du chargeur (connexion au réseau 220V et cycle de charge). Le pro sport est disponible en deux modèles et peut être utilisé en 12 ou 24 V.

► Utilisation

Suivre la notice d'installation ci dessous pour la mise en place du chargeur.

Assurez vous que votre chargeur ainsi que les batteries se trouvent dans un endroit ventilé. Connecter la rallonge au chargeur sans que celle ci ne soit raccordée au secteur. Connecter ensuite la rallonge électrique à une prise protégée par un disjoncteur différentiel.

Une fois le chargeur connecté, il rechargera automatiquement les batteries leur assurant ainsi une durée de vie maximale. Dans la mesure du possible, il est recommandé de laisser le chargeur branché en permanence, cela assure le maintien d'une charge d'entretien, prévient des problèmes de sulfatation et vous permet d'avoir des batteries en permanence complètement chargées.

► Alimentation 220V et leds d'état

indicateur vert « AC power »: Lorsque cette led est verte, cela indique que le chargeur est raccordé au 220V.

Indicateur rouge « charging »: Quand cette led est allumée, cela indique que le chargeur est en train de compléter le cycle de charge.

Quand le cycle de charge est terminé (charge d'entretien), seule la led verte reste allumée.

► Aperçu du cycle de charge automatique

Quand le chargeur vient d'être connecté, la led verte (secteur ou ac power) passe au vert, elle est ensuite suivie par la led rouge qui indique que le cycle de charge est lancé.

Pro sport (phase de boost) – Led rouge et verte allumées
Pendant cette phase le chargeur rechargera les batteries à sa puissance maximum jusqu'à ce que les batteries atteignent une tension de 14,1V (adapté pour les batteries sans entretien ou les batteries gel /AGM).

Pro sport (phase d'absorption) – Led rouge et verte allumées
Une fois la tension de 14,1V atteinte les batteries seront maintenues à cette tension afin de compléter la charge. Après cette étape, le chargeur passera en charge d'entretien (floating).

▶ Aperçu du cycle de charge automatique (suite) ▶

Pro sport (phase entretien) – Led verte allumée

Dans cette phase, la led rouge sera éteinte. Ceci indique que le cycle de charge est terminé et que le chargeur maintient désormais une charge d'entretien. Seule la led verte sera allumée durant cette phase. La tension des batteries est maintenue à 13,5V afin de les maintenir chargées, cette tension est parfaitement adaptée pour entretenir les batteries lorsqu'elles ne sont pas utilisées.

Note: Seule la led verte restera allumée pendant la phase d'entretien.

Tensions de charge typiques

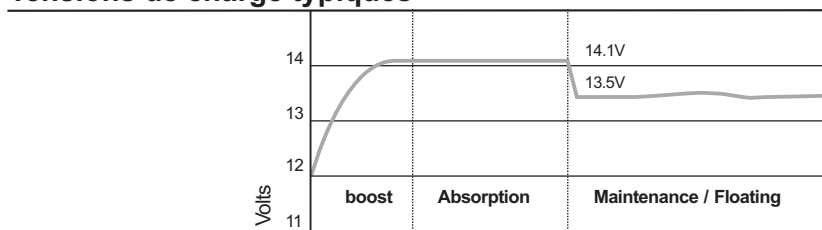

▶ Installation

Tous les chargeurs de batteries pro sport sont conçus pour être installés de façon définitive à bord. Ils peuvent aussi bien être installés en position horizontale que verticale.

Veiller à installer le chargeur dans un endroit qui sera correctement ventilé lorsqu'il sera en marche.

Ne pas brancher le chargeur ou les batteries avant d'avoir complété les étapes ci dessous:

1. Trouver un endroit ventilé avec un espace de 25 cm minimum d'air libre autour du chargeur . Ouvrir le compartiment moteur et les compartiments batteries pendant 15 min avant de procéder à l'installation du chargeur.
2. Ne pas installer le chargeur sur de la moquette. Assurez vous que le chargeur soit placé dans un endroit accessible où les indicateurs de charge sont visibles. Assurez vous aussi que les câbles de batteries sont suffisamment longs pour atteindre celles ci.

Installation Suite

3. En utilisant le chargeur comme modèle, utiliser un tournevis pour marquer les quatre trous de fixation.
4. Percer les trous de fixation adaptés aux vis aux emplacements déterminés en point 3).
5. Mettre en place le chargeur à l'emplacement sélectionné en utilisant des vis inoxydables non incluses.
6. Préparer la cosse de la batterie avec une brosse afin d'obtenir une surface propre.

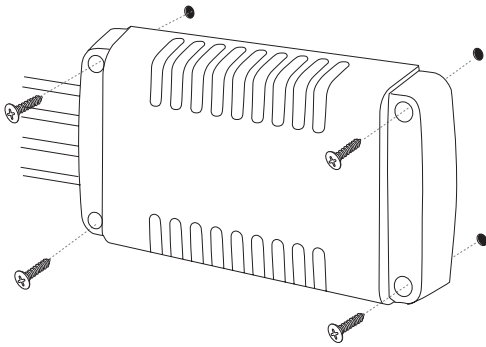

Note importante

Vérifier que la surface utilisée est suffisamment robuste et épaisse pour supporter le chargeur avec les vis que vous avez sélectionnées.

7. Passer les câbles en évitant les objets coupants et en les fixant à l'aide de colliers. Ne pas raccourcir les câbles dans la mesure où des fusibles sont mis en place 10 cm avant l'extrémité de chaque câble rouge en cas de court circuit ou d'inversement de polarité.
8. Connecter la sortie du chargeur aux batteries comme illustré en page 8. Assurez vous que le câble noir ou jaune sont connectés comme illustré à la borne négative de la batterie, et que le câble rouge est connecté à la borne positive.
9. Assurez vous que les connexions vers les batteries sont correctes et tiennent solidement.
10. Placer la prise de courant alternatif dans un endroit bien ventilé du bateau et à au moins 60 cm du chargeur, des batteries ou des tuyaux de carburant.

Connecter maintenant le chargeur au réseau 220V. Regarder les leds du chargeur. En supposant que vos batteries soient déchargées, vous devez voir à la fois la led verte et la led rouge allumées. Ceci indique que le cycle de charge est en cours.

Batteries au plomb ouvert / fermé, gel et AGM

Le chargeur pro charge est programmé avec un cycle de charge en mesure de charger tout type de batteries (gel, AGM, plomb ouvert ou sans entretien).

ProSport: Schéma de câblage

Si seulement deux batteries sont utilisées avec un chargeur de batteries permettant de charger trois parcs, connecter les deux câbles utilisés sur le parc de batteries qui sera le plus amené à être déchargé.

Note importante: Veiller à toujours connecter les sorties du chargeur sur une batterie (un parc de batteries 12V) même lorsque les batteries sont câblées en série pour obtenir un parc 24V.

ProSport Câblage

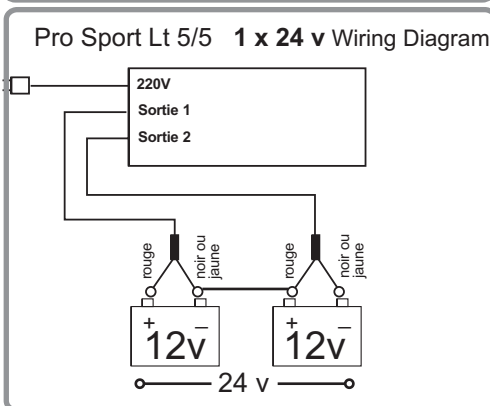
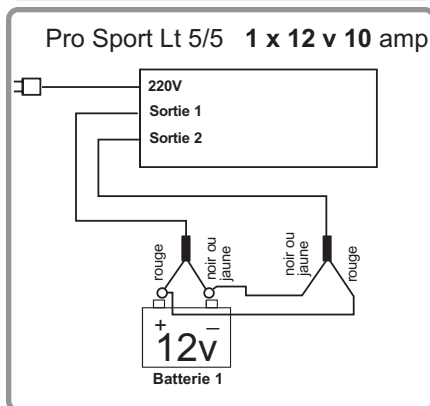
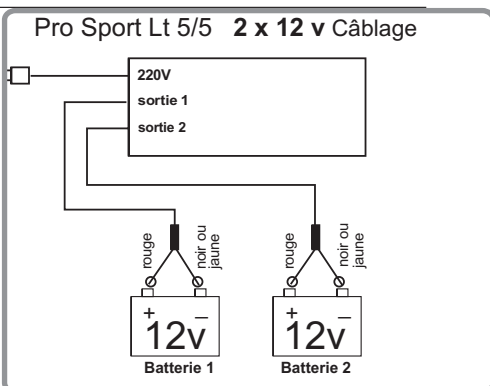
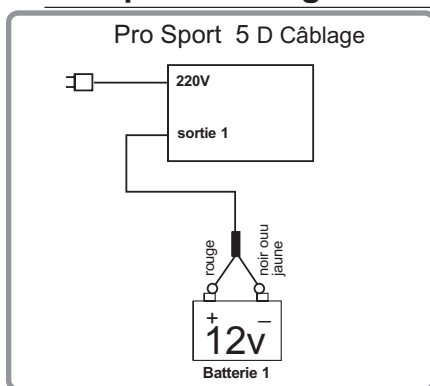

Recharge des batteries

La série pro sport est conçue pour charger et maintenir la charge des batteries. Respecter les étapes suivantes lorsque vous rechargez vos batteries:

1. Ouvrir les compartiments batteries et les ventiler durant 15 min avant de brancher le chargeur sur le 220V. Durant la charge, assurez vous que le compartiment batteries soit correctement ventilé.

► Recharge des batteries suite

2. Connecter une rallonge 220V au chargeur pro sport. Connecter ensuite la rallonge à une prise de courant correctement protégée (protection avec un disjoncteur différentiel).
3. Assurez vous que la led verte et la led rouge sont allumées. Cela confirme que le cycle de charge est en cours.
4. Laisser les batteries en charge jusqu'à l'extinction de la led rouge. Cela indique que les batteries sont complètement chargées et qu'elles sont maintenues en charge d'entretien. Le chargeur peut être laissé branché en permanence lorsque les batteries sont non utilisées, cela permet de les maintenir chargées.
5. Lorsque vous voulez utiliser votre bateau, débrancher la rallonge de courant du secteur en premier lieu puis débrancher le chargeur de la rallonge.

► Note importante sur la réglementation FCC

Ce chargeur pro sport a été conçu et testé pour respecter les standard FCC classe A partie 15. Ces normes assurent une protection contre les interférences dans le cadre d'une application commerciale. Si vous constatez des interférences sur la radio ou la télévision, débrancher simplement le chargeur pour confirmer qu'il est à l'origine des interférences.

Si c'est le cas, vous pouvez essayer les étapes suivantes pour tenter de résoudre le problème:

1. Utiliser une autre prise pour alimenter le chargeur
2. Assurez vous que la prise est correctement reliée à la terre
3. Re positionner l'antenne réceptrice
4. Acheter un filtre de bruit séparé

Guide d'entretien du chargeur

Item: Connexion des batteries	
Action:	Nettoyer et vérifier les connexions batteries. Suivre les instructions du fabricant pour nettoyer vos batteries. Utiliser une brosse métallique pour nettoyer les batteries et resserrer les cosses si nécessaire.
Périodicité	Mensuelle
Item: Niveau d'électrolyte des batteries	
Action:	Pour les batteries à entretien, vérifier le niveau de l'électrolyte
Périodicité	Mensuelle
Item: Câbles de charge	
Action:	Vérifier les câbles de connexions du chargeur. En cas de coupure ou d'usure du câble, le chargeur doit être renvoyé.
Périodicité	Mensuelle
Item: Câble d'alimentation 220V	
Action:	Vérifier les câbles de connexions du chargeur. En cas de coupure ou d'usure du câble, le chargeur doit être renvoyé.
Périodicité	Mensuelle

► Guide de dépannage

La led verte et la led rouge ne s'allument pas

Vérifier que la prise est bien connectée. Vérifier que le disjoncteur est bien positionné. Vérifier avec un voltmètre que la tension 220V est bien disponible au niveau de la prise

Vérifier que les câbles du chargeur sont connectés avec la bonne polarité et que les connexions aux batteries sont propres et bien serrées.

Après avoir débranché le chargeur et le moteur arrêté, vérifier la tension des batteries. Si la tension des batteries est nulle, cela signifie que les batteries sont défectueuses et qu'il faut les remplacer.

Si tous les tests précédents se révèlent positifs, il faut retourner le chargeur pour maintenance.

La batterie ne se charge pas et les leds rouge et verte sont allumées

Vérifier que les câbles du chargeur sont connectés avec la bonne polarité et que les connexions aux batteries sont propres et bien serrées. Un inversement de polarité conduit au claquage du fusible, par conséquent, l'appareil ne délivre plus de courant.

Avec le chargeur allumé, vérifier la tension sur chacune des batteries. Si la tension sur l'une des batteries est inférieure à 13V, procéder comme suit:

1. Déconnecter la prise 220V

2. Enlever les câbles du chargeur vers les batteries

3. Reconnecter la prise 220V. Si la tension de sortie de chacun des câbles du chargeur est proche de 14,1V, celui-ci fonctionne correctement. Chacune des batteries doit être testée pour confirmer son bon état.

4. Si il n'y a pas de tension, vérifier les fusibles se trouvant sur le câble positif du chargeur et les changer si nécessaire.

Si la tension de charge est inférieure à 13V, veuillez retourner le produit pour maintenance.

► Specifications

model	volts	amps	nb parcs	DC cable L	Dim L	x l	x H mm	Poids	AC in
Pro Sport	12	5	1	1.5 m	75	x 150	x 65	2.5 kg	180-260
Pro Sport	12 & 24	10	2/2	1 x 1.5 m	230	x 130	x 90	3.5 kg	180-260

► Garantie

Ce produit a été conçu pour vous donner entière satisfaction et est garanti pendant deux ans. Si pendant la période de garantie, vous rencontrez le moindre problème, veuillez contacter votre revendeur pour qu'il en assure la maintenance.

www.sterling-power.com